

**CROWN**

# SH 5500 SERIES

## Specifications

Heavy-Duty Walkie  
Straddle Stacker





# SH 5500 Series

# Specifications

			<i>Imperial</i>	<i>Metric</i>	<i>Imperial</i>	<i>Metric</i>		
<b>General Information</b>	1	<b>Manufacturer</b>	<b>Crown Equipment Corporation</b>					
	2	<b>Model</b>	<b>SH 5520-40</b>		<b>SH 5540-40</b>			
	3	<b>Load Capacity</b>	lb kg	See Chart				
	4	<b>Load Center</b>	in mm	24	600	24	600	
	5	<b>Power</b>	Electric	24 Volts				
	6	<b>Operator Type</b>	Walkie	Stacker				
	7	<b>Tire Type</b>	Load / Drive	Poly / Poly				
	8	<b>Wheels (x = driven)</b>	Load / Drive	4 / 1x				
<b>Dimensions</b>	9	<b>Lift Height</b>	in mm	See Chart				
	13	<b>Head Length*</b>	in mm	36.8	935	43.3	1100	
	14	<b>Wheelbase</b>	in mm	51.4	1305	57.9	1470	
	15	<b>Turning Radius</b>	in mm	58.2	1480	64.8	1650	
	16	<b>Inside Straddle</b>	in mm	34 - 50" in 2" increments	865 - 1270 mm in 50 mm increments	34 - 50" in 2" increments	865 - 1270 mm in 50 mm increments	
	17	<b>Forks</b>	Standard L x W x T	in mm	36 x 4 x 1.75	915 x 102 x 44	36 x 4 x 1.75	915 x 102 x 44
Optional Lengths			in mm	30, 39, 42, 45, 48, 54, 60	760, 990, 1060, 1145, 1220, 1370, 1525	30, 39, 42, 45, 48, 54, 60	760, 990, 1060, 1145, 1220, 1370, 1525	
<b>Performance</b>	18	<b>Travel Speeds</b>	Empty / Loaded	mph km/h	3.7 / 3.4	5.9 / 5.4	3.7 / 3.4	5.9 / 5.4
	19	<b>Lift Speeds</b>	Empty / Loaded	fpm m/s	48.4 / 29.5	.245 / .145	48.4 / 29.5	.245 / .145
	20	<b>Lowering Speeds</b>	Empty / Loaded	fpm m/s	50 / 50	.250 / .250	50 / 50	.250 / .250
	21	<b>Grade Clearance</b>		%	9	9	8	8
	22	<b>Battery</b>	Min Weight / Max Amp	lb kg	510 / 300	235 / 290	975 / 660	445 / 585
Max Battery Size W x L x H			in mm	6.62 x 34.37 x 24.8	168 x 873 x 630	13.12 x 31.10 x 24.8	333 x 790 x 630	
			Cable Lead Length / Connector Position	in mm	20 / B	510 / B	20 / B	510 / B

\* Add 2.1" (55 mm) for Sideshift

<b>Mast Type</b>			<b>TL – Limited Free Lift</b>				<b>TT – Triple Telescopic</b>					
			<i>Imperial</i>	<i>Metric</i>	<i>Imperial</i>	<i>Metric</i>	<i>Imperial</i>	<i>Metric</i>	<i>Imperial</i>	<i>Metric</i>		
<b>Mast and Weight</b>	9	<b>Lift Height</b>	in mm	127.5	3235	150.5	3820	156	3960	192	4875	
	3	<b>Load Capacity</b>	SH 5520-40	lb kg	4000	1810	4000	1810	4000	1810	na	na
			SH 5540-40	lb kg	4000	1810	4000	1810	4000	1810	4000*	1810*
	10	<b>Free Lift</b>	without LBR	in mm	6	150	6	150	52.5	1330	66.5	1685
	11	<b>Collapsed Height</b>		in mm	83.5	2120	95.5	2425	75	1905	89	2260
	12	<b>Extended Height**</b>		in mm	150	3810	173	4395	178.5	4535	214.5	5450
	23	<b>Min ID Straddle Width</b>		in mm	34	865	34	865	38	965	42	1065
24	<b>Truck Weight without Battery***</b>	SH 5520-40	lb kg	3025	1375	3130	1420	3570	1620	na	na	
		SH 5540-40	lb kg	2840	1290	2945	1335	3385	1535	3620	1640	

\* Up to 156" (3960 mm), 3000 lb (1360 kg) at 192" (4875 mm)

\*\* Add 24.7" (9630 mm) with Load Backrest

\*\*\* Add 85 lb (40 kg) for Load Backrest

Add 120 lb (55 kg) for Sideshift

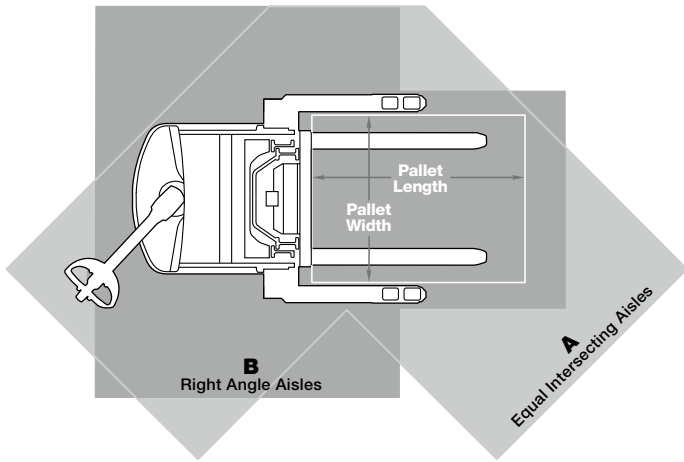

SH 5520

Pallet Width		Pallet Length in (mm)									
		30 (762)		36 (915)		40 (1016)		42 (1067)		48 (1220)	
		A	B	A	B	A	B	A	B	A	B
<b>36</b> 915	in mm	62 1575	78 1980	62 1575	81 2060	62 1575	87 2210	62 1575	89 2260	63 1600	96 2450
<b>40</b> 1016	in mm	65 1650	78 1980	65 1650	81 2060	65 1650	87 2210	65 1650	90 2285	65 1650	97 2465
<b>42</b> 1067	in mm	66 1680	78 1980	66 1680	81 2060	66 1680	87 2210	66 1680	90 2285	66 1680	97 2465
<b>48</b> 1220	in mm	69 1750	79 2005	69 1750	81 2060	69 1750	88 2235	69 1750	91 2310	70 1780	98 2490

SH 5540

Pallet Width		Pallet Length in (mm)									
		30 (762)		36 (915)		40 (1016)		42 (1067)		48 (1220)	
		A	B	A	B	A	B	A	B	A	B
<b>36</b> 915	in mm	66 1675	83 2110	66 1675	86 2185	66 1675	92 2340	66 1675	94 2390	66 1675	102 2590
<b>40</b> 1016	in mm	68 1730	83 2110	68 1730	86 2185	68 1730	92 2340	68 1730	95 2415	68 1730	102 2590
<b>42</b> 1067	in mm	69 1755	84 2135	69 1755	87 2210	69 1755	93 2365	69 1755	95 2415	69 1755	103 2615
<b>48</b> 1220	in mm	72 1830	84 2135	72 1830	87 2210	72 1830	93 2365	72 1830	96 2450	73 1855	104 2640

A = Equal Intersecting Aisles  
B = Right Angle Aisles

Add 2.5" (65 mm) if sideshift option is used.  
Add 6" (150 mm) to 12" (300 mm) to all aisle dimensions for maximum maneuverability.

Capacity

4000 lb (1810 kg) at 24" (600 mm) load center

Maximum Battery Size

SH 5520-40: 6.62" wide x 34.37" long x 24.8" high (168 x 873 x 630 mm) – up to 300 amp hours, 24 volts

SH 5540-40: 13.12" wide x 31.10" long x 24.8" high (333 x 790 x 630 mm) – up to 660 amp hours, 24 volts

Standard Equipment

- 24-volt electrical system
- Crown's Access 1 2 3® Comprehensive System Control
- Access 1 2 3 display
  - Eight-character scrolling display, 5 button access
  - Three selectable performance levels
  - BDI with lift interrupt
  - Five hour meters
  - Event codes

- Access 1 2 3 diagnostics with real time troubleshooting
  - PIN code capability
- AC traction and steer motors
  - Performance enhancing features
    - X10® Handle
    - Brake override
    - Electronic power steering
    - Ramp hold and speed control
    - Power boost
    - High-visibility mast and carriage
    - Low profile power unit
    - Tool storage tray
  - Wire mesh guard - mast
  - Poly high-capacity drive tire – 10" dia. x 3" wide (250 x 75 mm)
  - Polyurethane load wheels – 4" dia. x 2.88" wide (100 x 74 mm)
  - InfoPoint® System

SH 5500 Series

- Steel power unit covers
- Emergency power disconnect
- Key switch
- Horn
- SB175 gray battery connector
- Reversing button
- Electric park brake
- Fork tip indicators
- Battery compartment rollers

Optional Equipment

- 30 amp on-board charger (6.62" [168 mm] battery box)
- Keyless on-off switch
- Work Assist® Accessories:
  - Clip pad
  - Hook
  - Clip pad and hook
  - Pocket
  - Fan

Technical Information

- Sideshift with internal hosing 4" (100 mm) sideshift each direction – Reduces capacity 300 lb (140 kg)
- 32.8" wide x 47" tall load backrest (835 x 1195 mm)
- Optional fork lengths (30", 39", 42", 45", 48", 54", 60") (760, 990, 1060, 1145, 1220, 1370, 1525 mm)
- Freezer Package (Continuous -29 °C / -20 °F)
- Plexiglass safety shield
- 10" dia. x 4" wide drive tire (250 x 100 mm)
  - Soft poly
  - Siped soft poly
- InfoLink® Ready
- SBE 160 battery connector
- EE Rating

### Operator Controls

Crown's robust X10 handle places all control buttons in the optimum position for ease of operation with either hand and to minimize hand and wrist movements. An ergonomic forward/reverse thumb wheel allows for precise maneuvering. The control hand grips are urethane covered for insulation from cold and vibration with integrated horn buttons for easy activation. The handle contains a safety button which reverses the direction of the truck should the button touch the operator.

The physical efforts to hold the handle at a comfortable height was minimized to reduce fatigue.

A rabbit/turtle switch incorporates two levels of programmable travel performance so operators can select the setting that matches their experience level or application requirements.

Exclusive brake override feature allows slow speed travel with the handle near vertical. This feature improves maneuverability in tight areas.

### Performance

The SH 5500 Series incorporates the latest generation AC drive system enhanced with Access 1 2 3 technology. Crown's Access 1 2 3 technology continuously monitors truck systems and adjusts system parameters to deliver optimum performance and control. The Access Display provides a convenient interface for operators keeping them informed of any changes impacting truck performance and allowing them to choose from three performance profiles when enabled.

Programmable performance settings enable authorized personnel to tune the lift truck to different operator skill levels, or to meet specific application requirements. In addition, up to 25 PIN codes can be assigned to individual operators and matched to one of the pre-programmed performance profiles if desired.

Electronic power steering allows the operator to maneuver heavy loads in tight spaces throughout the day while minimizing fatigue. Smooth travel and lift performance combine with excellent controls provided by the X10 handle to increase productivity.

The SH 5500 Series features ramp hold and speed control to improve operation on small inclines or ramps. The ramp hold feature uses the motor to prevent truck movement when the brake is released and no travel command is present. The ramp speed control feature insures that actual travel speed matches requested travel speed. If the truck encounters an obstacle, a power boost feature delivers up to 15 percent more power than normally available for a full three seconds to overcome the obstruction.

### Electrical System

A heavy-duty 24-volt fused electrical system utilizes microprocessor controls for maximum energy efficiency, reduced maintenance and infinite speed control capability.

Access control modules for travel, lift and steer are sealed from dirt, dust and moisture for trouble-free operation. All contactors have been eliminated except for the main line contactor. A 175 amp battery connector with disconnect handle is standard.

### Hydraulic System

Heavy-duty hydraulic motor (4.8 kw) is transistor controlled and matched with a gear type pump selected for optimum lift performance and low noise. Single-speed lift with programmable acceleration - deceleration and programmable two-speed lowering enables customization to match operator preference or application requirements.

Cylinder rods are hard-plated chrome with polyurethane seals. Relief valve tuned to capacity protects all components in the hydraulic system. Reservoir incorporates an in-tank 10 micron return filter for removing debris from oil.

### Drive Unit / Brake

Heavy-duty gearbox with helical spur input gear for quiet operation.

Regenerative motor braking is activated under a downhill condition, during plugging or when the directional control is returned to neutral. An electro-magnetic brake, spring applied and electrically released, is mounted on top of the drive motor. The electro-magnetic brake serves as the parking brake and applies when the control handle position moves from the operating zone to brake zone during truck operation.

### Power Steering

Electronic power steering is provided by a heavy-duty AC motor that pivots the drive unit when steer tiller movement is detected.

### Mast

High visibility two and three-stage mast design with angled cross bracing and lift cylinders located behind nested I-beams provides maximum visibility for load positioning and placement. Crown's staging cushions coupled with lowering dampers ensure smooth operation.

Rolled steel outer mast channels and inner I-beams roll on canted, steel, anti-friction roller bearings for minimal current draw and long life. Mast and chain rollers are sealed and lubricated for life. Telescoping mast sections nest to reduce truck length. Heavier mast cross bracing design increases stiffness.

### Serviceability / Durability

The Access display simplifies service for technicians by providing advanced diagnostics without the need for separate handsets. The display allows the technician to view event service codes and truck hours when event occurred, perform system calibrations or functional tests of components, and make necessary adjustments. Crown's InfoPoint System compliments Access 1 2 3 diagnostics by providing a Quick Reference Guide, on-truck component maps and information nuggets to further simplify troubleshooting. All wiring is color coded.

Removable steel power unit doors are hinged for ease of opening providing excellent accessibility to the distribution panel and all other components. Steel covers provide added protection to critical internal components.

Removable steel battery covers and hinged cover allow easy access to the battery. Battery removal can be accomplished from either side. Battery compartment rollers are standard.

The X10 handle incorporates a vacuum die cast process using high-grade aluminum and benefits from structural webbing for maximum strength and durability.

### Warning Device Options

Audible or Visual Alerts

Safety considerations and dangers associated with audible travel alarms and lights include:

- Multiple alarms and/or lights can cause confusion.
- Workers ignore the alarms and/or lights after day-in and day-out exposure.
- Operator may transfer the responsibility for "looking out" to the pedestrians.
- Annoys operators and pedestrians.

### Other Options Available

Contact factory for additional options.

*Dimensions and performance data given may vary due to manufacturing tolerances. Performance is based on an average size vehicle and is affected by weight, condition of truck, how it is equipped and the conditions of the operating area. Crown products and specifications are subject to change without notice.*



**Crown Equipment Corporation**

New Bremen, Ohio 45869 USA

**Tel** 419-629-2311

**Fax** 419-629-3796

[crown.com](http://crown.com)

**You can count on Crown to build lift trucks designed for safe operation, but that's only part of the safety equation. Crown encourages safe operating practices through ongoing operator training, safety-focused supervision, maintenance and a safe working environment. Go to [crown.com](http://crown.com) and view our safety section to learn more.**

Because Crown is continually improving its products, specifications are subject to change without notice.

Crown, the Crown logo, the color beige, the Momentum symbol, Access 1 2 3, InfoPoint, InfoLink and X10 Handle are trademarks of Crown Equipment Corporation in the United States and other countries.

Copyright 2008-2019 Crown Equipment Corporation  
SF14905 Rev. 11-19  
Printed in U.S.A.